

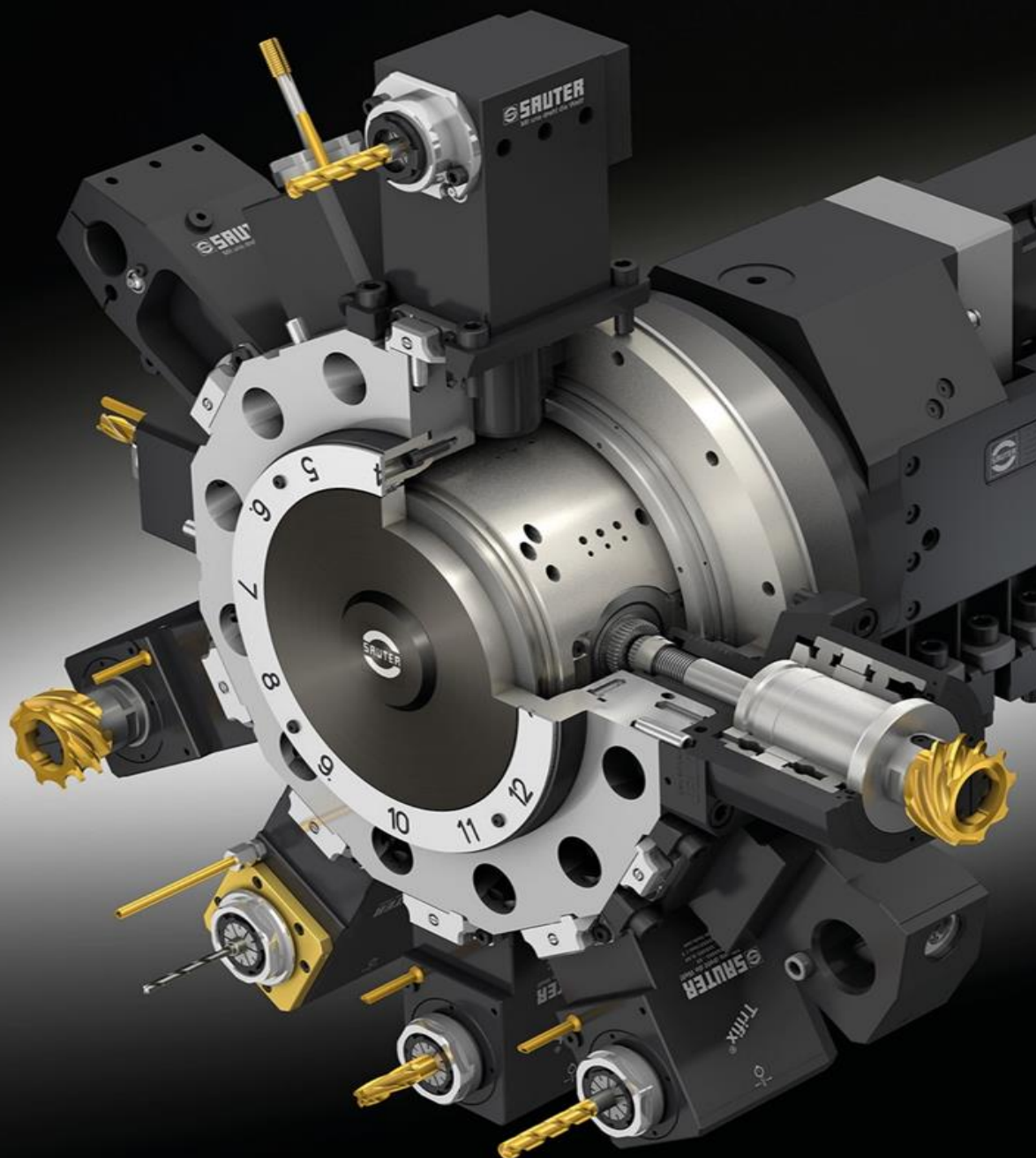

# Tooling Katalog BMT65

## Tooling catalog BMT65



Stand Mai 2024

## **FLEXIBEL. PROZESSSICHER. AUTOMATISIERBAR.**

SAUTER Tooling startet als einfaches, kostengünstiges Spannzangensystem und kann mit Ihren Anforderungen ausgebaut werden – bei Bedarf bis zum vollautomatisierbaren Schnellwechselsystem. Ausgehend von der Basis-Version und einem Upgrade-Set sind hierfür keine weiteren Investitionen erforderlich, um in die Automatisierung einzusteigen.

SAUTER bietet Ihnen ein neues System, das mit Ihren Anforderungen mitwächst.



### **Bereits in der Basis-Ausführung enthalten:**

- \_ Geeignet für hohe Drehzahl bis zu 14.000 1/min
- \_ Spezielles SAUTER Dichtungssystem
- \_ 100 % Trockenlaufeignung bei Werkzeugen mit interner Kühlmittelzufuhr
- \_ Ausgestattet mit SAUTER Hochgenauigkeitslagern
- \_ Im Standard als 2-in-1-System mit ER Spannzange ausgeführt – Mit Upgrade-Set\* umrüstbar auf das neue modulare Schnellwechselsystem SAUTER SolidPro®

(\*im Standard-Lieferumfang nicht enthalten)

## **FLEXIBLE. PROCESS RELIABLE. AUTOMATED.**

SAUTER Tooling starts as a simple, cost-effective collet system and can be expanded as required – up to a fully automatic quick-change system if necessary. Starting with the basic version and an upgrade set, no further investment is required to get started with automation.

SAUTER offers you a new system that grows with your requirements.



### **Already included in the basic version:**

- \_ Suitable for high speeds up to 14,000 rpm
- \_ Special SAUTER sealing system
- \_ 100% dry-running suitability for tools with internal coolant supply
- \_ Equipped with SAUTER high-precision bearings
- \_ Designed as a 2-in-1 system with ER collet as standard – Can be converted to the new modular SAUTER SolidPro® quick-change system with an upgrade set\*

(\*not included in the standard delivery)

Neue Tooling Generation  
 von SAUTER - Upgrade  
 auf neues modulares  
 Schnellwechselsystem  
**SAUTER SolidPro®**

**Volle Flexibilität:**

- \_ Mit Upgrade-Set vom Standard Tooling zum modularen Schnellwechselsystem
- \_ Maschinenrüstzeiten reduzierbar durch voreingestellte Adapter
- \_ Adapter sind mit Standard-Inbusschlüssel zu bedienen - kein Sonderschlüssel erforderlich
- \_ SAUTER SolidPro® bietet zusätzlich die Voraussetzung für den Einstieg zur vollen Automation
- \_ Alle Möglichkeiten, um Ihre Fertigung manuel, teil-automatisiert oder voll-automatisch durchzuführen

**Leistungsdaten:**

- \_ Hohe Drehzahl bis zu 14.000 1/min
- \_ 100 % Trockenlaufleistung
- \_ Spezielle Sauter Hochgenauigkeitslager

New tool generation  
 from SAUTER - Upgrade  
 to modular quick-change  
 system  
**SAUTER SolidPro®**

**Full flexibility:**

- \_ With upgrade set from standard tool holder to modular quick-change system
- \_ Set-up times can be reduced thanks to pre-set adapters
- \_ Adapters can be operated with a standard key - no special key required
- \_ SAUTER SolidPro® also offers the prerequisite for entry into full automation
- \_ All the options you need to manual, semi-automated or fully automated production

**Performance data:**

- \_ High speed up to 14,000 rpm
- \_ 100% dry-running
- \_ Special high-precision bearings



**SAUTER SolidPro® makes the next level of automation possible**



+



SAUTER SolidPro®  
 Schnittstelle  
 interface

+



Roboter  
 Robots

= volle  
**Automation**  
 full  
 automation

SolidPro® - Adapter	Werkzeugaufnahme <i>Tools Clamping</i>	Spannbereich [mm] <i>Clamping range [mm]</i>	Bestell-Nr. <i>Ordering N°</i>	
	Sauter SolidPro®	SP32	<b>179393</b>	
	Spannzange <i>Collet chuck</i> ISO15488/DIN6499	ER25-I	1-16	<b>179463</b>
		ER20-I	1-13	--
	Spannzange <i>Collet chuck</i> ISO15488/DIN6499	ER32-A	2-20	<b>179464</b>
		ER25-A	1-16	--
	Weldon <i>Weldon</i> DIN1835-B	20		<b>179399</b>
		16		<b>179459</b>
		12		<b>179460</b>
		10		<b>179461</b>
		8		<b>179465</b>
		6		<b>179462</b>
	Fräsdorn <i>shell end mill arbor</i> DIN 6358	27		<b>179900</b>
		22		<b>179899</b>
		16		<b>179402</b>
	Rohling <i>Adapter for customized solutions</i>			<b>179476</b>

**BMT 65**  
(Doosan Style)

Werkzeug- aufnahme	Überset- zung	Ausricht- system	Max. Geschwind. [1/min]	Nennhöhe [mm]	Version	Kühlschmier- stoffzufuhr	Bestell-Nr.
<i>Tool Clamping</i>	<i>Ratio</i>	<i>Alignment System</i>	<i>Max. Speed [rpm]</i>	<i>Nominal height [mm]</i>	<i>Version</i>	<i>Coolant supply</i>	<i>Order N°</i>

(Abb. ähnlich)/(Fig. similar)



Spannzange-ER 32* collet chuck ER32*	i=1:1	Ausrichtung Nutenstein slut nut alignment system	14000	80	UNI	extern/ intern	179331
---	-------	--	-------	----	-----	----------------	--------



Spannzange-ER 32* collet chuck ER32*	i=1:1	Ausrichtung Nutenstein slut nut alignment system	14000	90	UNI	extern/ intern	179174
---	-------	--	-------	----	-----	----------------	--------



Spannzange-ER25 winkeleinstellbar collet chuck ER25 angle adjustable	i=1:1	Ausrichtung Nutenstein slut nut alignment system	6000	75	UNI	extern/ intern	178071
						extern	178062

\*Upgrade auf modulares Schnellwechselsystem Sauter SolidPro möglich. Umbausatz Bestell-Nr.: 179393  
 \*Upgrade to modular quick-change system Sauter SolidPro possible. Conversion kit Order-No.: 179393  
 (nicht im Lieferumfang enthalten / not included in delivery)

**BMT 65**

Modell	Werkzeug-aufnahme	Nennhöhe [mm]	Version	Kühlschmierstoffzufuhr	Bestell-Nr.
<i>Model</i>	<i>Tool clamping</i>	<i>Nominal height [mm]</i>	<i>Version</i>	<i>Coolant supply</i>	<i>Order N°</i>

(Abb. ähnlich)/(Fig. similar)



Bohrstangenhalter  
Boring bar holder

	Ø 40 mm	72	UNI	extern/ intern	178461
		100	UNI		178566
	Ø50 mm	72	UNI		178563



Werkzeughalter mit  
Vierkantaufnahme  
square tool holder

25 mm	80	UNI	extern	178558
-------	----	-----	--------	--------



Werkzeughalter mit  
Vierkantaufnahme  
square tool holder

25 mm	80	UNI	extern	178560
-------	----	-----	--------	--------



Werkzeughalter mit  
Vierkantaufnahme  
square tool holder

20 mm	75	UNI	extern	178454
-------	----	-----	--------	--------



Werkzeughalter mit  
Vierkantaufnahme  
square tool holder

25 mm	70	UNI	extern	178457
-------	----	-----	--------	--------



Abstechhalter für  
Stechklingen  
cut off tool holder

32 mm	80	UNI	extern	178459
-------	----	-----	--------	--------